

# Component-Level Information Packet for 08590-60158

**BW Filter**

**Copyright © 1991 Hewlett-Packard Company**

**All Rights Reserved.  
Reproduction, adaptation, or translation  
without prior written permission  
is prohibited, except as allowed  
under the copyright laws.**

**HP Document Part Number 08590-90120**

**Printed December 1990  
Printed in USA**

The information contained in this document is subject to change without notice.





## HP Part Number 08590-60158

### BW Filter

Reference Designation	HP Part Number	C D	Qty	Description	Mfr Code	Mfr Part Number
C1	0160-4832	4	1	CAP-FXD 0.01uF 100 V	02010	SA101C103KAAH
C2	0160-4832	4	1	CAP-FXD 0.01uF 100 V	02010	SA101C103KAAH
C4	0160-4832	4	1	CAP-FXD 0.01uF 100 V	02010	SA101C103KAAH
C5	0160-4832	4	1	CAP-FXD 0.01uF 100 V	02010	SA101C103KAAH
C6	0160-4811	9	1	CAP-FXD 270pF +-5% 100 V CER COG	02010	SA101A271JAAH
C7	0160-4832	4	1	CAP-FXD 0.01uF 100 V	02010	SA101C103KAAH
C9	0160-4832	4	1	CAP-FXD 0.01uF 100 V	02010	SA101C103KAAH
C10	0160-5899	5	1	CAP-FXD 7.5pF 200 V	06352	DA12C0G2D7R5D
C11	0160-4789	0	1	CAP-FXD 15pF +-5% 100 V CER COG	02010	SA102A150JAAH
C12	0160-4832	4	1	CAP-FXD 0.01uF 100 V	02010	SA101C103KAAH
C13	0160-4799	2	1	CAP-FXD 2.2pF +-11.36% 100 V CER COG	02010	MA101A2R2CAAH
C14	0160-0437	7	1	CAP-FXD 12pF 500 V	09538	301-000-P3K0-120J
C15	0121-0059	7	1	CAP-VAR 8pF 2pF 350 V	01468	304-324-139
C16	0160-4832	4	1	CAP-FXD 0.01uF 100 V	02010	SA101C103KAAH
C17	0121-0059	7	1	CAP-VAR 8pF 2pF 350 V	01468	304-324-139
C18	0160-4832	4	1	CAP-FXD 0.01uF 100 V	02010	SA101C103KAAH
C19	0160-4832	4	1	CAP-FXD 0.01uF 100 V	02010	SA101C103KAAH
C20	0160-4832	4	1	CAP-FXD 0.01uF 100 V	02010	SA101C103KAAH
C21	0160-4832	4	1	CAP-FXD 0.01uF 100 V	02010	SA101C103KAAH
C22	0160-4832	4	1	CAP-FXD 0.01uF 100 V	02010	SA101C103KAAH
C23	0121-0036	0	1	CAP-VAR 18pF 5.5pF 350 V	01468	304-324-237
C24	0140-0205	5	1	CAP-FXD 62pF 300 V MICA	02367	CD15ED620J03
C25	0121-0059	7	1	CAP-VAR 8pF 2pF 350 V	01468	304-324-139
C26	0160-5407	1	1	CAP-FXD 62pF 100 V	02010	SA102A620JAAH
C27	0160-4832	4	1	CAP-FXD 0.01uF 100 V	02010	SA101C103KAAH
C28	0160-4832	4	1	CAP-FXD 0.01uF 100 V	02010	SA101C103KAAH
C29	0160-4835	7	1	CAP-FXD 0.1uF 50 V	02010	SA115C104KAAH
C30	0160-4832	4	1	CAP-FXD 0.01uF 100 V	02010	SA101C103KAAH
C31	0160-4832	4	1	CAP-FXD 0.01uF 100 V	02010	SA101C103KAAH
C32	0160-4786	7	1	CAP-FXD 27pF +-5% 100 V CER COG	02010	SA102A270JAAH
C33	0160-4832	4	1	CAP-FXD 0.01uF 100 V	02010	SA101C103KAAH
C35	0160-4831	3	1	CAP-FXD 4700pF 100 V	02010	SA101C472KAAH
C36	0160-4811	9	1	CAP-FXD 270pF +-5% 100 V CER COG	02010	SA101A271JAAH
C37	0160-4832	4	1	CAP-FXD 0.01uF 100 V	02010	SA101C103KAAH
C38	0121-0059	7	1	CAP-VAR 8pF 2pF 350 V	01468	304-324-139
C39	0160-4789	0	1	CAP-FXD 15pF +-5% 100 V CER COG	02010	SA102A150JAAH
C40	0160-5899	5	1	CAP-FXD 7.5pF 200 V	06352	DA12C0G2D7R5D
C41	0160-4832	4	1	CAP-FXD 0.01uF 100 V	02010	SA101C103KAAH
C42	0160-4832	4	1	CAP-FXD 0.01uF 100 V	02010	SA101C103KAAH
C43	0160-4799	2	1	CAP-FXD 2.2pF +-11.36% 100 V CER COG	02010	MA101A2R2CAAH
C44	0160-0437	7	1	CAP-FXD 12pF 500 V	09538	301-000-P3K0-120J
C45	0121-0036	0	1	CAP-VAR 18pF 5.5pF 350 V	01468	304-324-237
C46	0160-4832	4	1	CAP-FXD 0.01uF 100 V	02010	SA101C103KAAH
C47	0121-0059	7	1	CAP-VAR 8pF 2pF 350 V	01468	304-324-139
C48	0160-4832	4	1	CAP-FXD 0.01uF 100 V	02010	SA101C103KAAH
C49	0160-4832	4	1	CAP-FXD 0.01uF 100 V	02010	SA101C103KAAH
C50	0160-4832	4	1	CAP-FXD 0.01uF 100 V	02010	SA101C103KAAH
C51	0160-4832	4	1	CAP-FXD 0.01uF 100 V	02010	SA101C103KAAH

\*Indicates factory-selected value

**HP Part Number 08590-60158**  
**BW Filter**

Reference Designation	HP Part Number	C D	Qty	Description	Mfr Code	Mfr Part Number
C52	0140-0205	5	1	CAP-FXD 62pF 300 V MICA	02367	CD15ED620J03
C53	0160-5407	1	1	CAP-FXD 62pF 100 V	02010	SA102A620JAAH
C54	0121-0059	7	1	CAP-VAR 8pF 2pF 350 V	01468	304-324-139
C55	0160-4832	4	1	CAP-FXD 0.01uF 100 V	02010	SA101C103KAAH
C56	0160-4832	4	1	CAP-FXD 0.01uF 100 V	02010	SA101C103KAAH
C57	0160-4835	7	1	CAP-FXD 0.1uF 50 V	02010	SA115C104KAAH
C58	0160-4832	4	1	CAP-FXD 0.01uF 100 V	02010	SA101C103KAAH
C59	0160-4796	9	1	CAP-FXD 3.9pF +-6.4% 100 V CER COG	02010	SA101A3R9CAAH
C60	0160-4832	4	1	CAP-FXD 0.01uF 100 V	02010	SA101C103KAAH
C61	0160-4832	4	1	CAP-FXD 0.01uF 100 V	02010	SA101C103KAAH
C62	0160-4832	4	1	CAP-FXD 0.01uF 100 V	02010	SA101C103KAAH
C63	0160-4832	4	1	CAP-FXD 0.01uF 100 V	02010	SA101C103KAAH
C64	0160-4832	4	1	CAP-FXD 0.01uF 100 V	02010	SA101C103KAAH
C65	0160-4832	4	1	CAP-FXD 0.01uF 100 V	02010	SA101C103KAAH
C66	0160-4832	4	1	CAP-FXD 0.01uF 100 V	02010	SA101C103KAAH
C67	0160-4832	4	1	CAP-FXD 0.01uF 100 V	02010	SA101C103KAAH
C68	0160-4832	4	1	CAP-FXD 0.01uF 100 V	02010	SA101C103KAAH
C69	0160-4832	4	1	CAP-FXD 0.01uF 100 V	02010	SA101C103KAAH
C70	0160-4832	4	1	CAP-FXD 0.01uF 100 V	02010	SA101C103KAAH
C71	0160-4535	4	1	CAP-FXD 1uF 50 V	02010	SR305C105KAAH
C72	0160-4535	4	1	CAP-FXD 1uF 50 V	02010	SR305C105KAAH
C73	0160-4832	4	1	CAP-FXD 0.01uF 100 V	02010	SA101C103KAAH
C74	0160-4832	4	1	CAP-FXD 0.01uF 100 V	02010	SA101C103KAAH
C75	0160-4832	4	1	CAP-FXD 0.01uF 100 V	02010	SA101C103KAAH
C76	0160-4832	4	1	CAP-FXD 0.01uF 100 V	02010	SA101C103KAAH
C77	0160-4832	4	1	CAP-FXD 0.01uF 100 V	02010	SA101C103KAAH
C78	0160-4806	2	1	CAP-FXD 39pF +-5% 100 V CER COG	02010	SA102A390JAAH
C79	0160-4535	4	1	CAP-FXD 1uF 50 V	02010	SR305C105KAAH
C80	0160-4380	7	1	CAP-FXD 1pF 200 V	06352	FD11C0K2D1ROC
CR1	1901-0050	3	1	DIODE-SWITCHING 80V 200MA 2NS DO-35	03334	BAV10 SELECTED
CR2	1901-0050	3	1	DIODE-SWITCHING 80V 200MA 2NS DO-35	03334	BAV10 SELECTED
CR3	1901-1070	9	1	DIODE-PIN 110V	02062	
CR4	1901-0535	9	1	DIODE-SCHOTTKY SM SIG	02062	
CR5	1901-1070	9	1	DIODE-PIN 110V	02062	
CR6	1901-0535	9	1	DIODE-SCHOTTKY SM SIG	02062	
CR7	1901-0050	3	1	DIODE-SWITCHING 80V 200MA 2NS DO-35	03334	BAV10 SELECTED
CR8	1901-0050	3	1	DIODE-SWITCHING 80V 200MA 2NS DO-35	03334	BAV10 SELECTED
CR9	1901-0050	3	1	DIODE-SWITCHING 80V 200MA 2NS DO-35	03334	BAV10 SELECTED
CR10	1901-1070	9	1	DIODE-PIN 110V	02062	
CR11	1901-0535	9	1	DIODE-SCHOTTKY SM SIG	02062	
CR12	1901-1070	9	1	DIODE-PIN 110V	02062	
CR13	1901-0535	9	1	DIODE-SCHOTTKY SM SIG	02062	
CR14	1901-0050	3	1	DIODE-SWITCHING 80V 200MA 2NS DO-35	03334	BAV10 SELECTED
L1	9100-3562	8	1	INDUCTOR RF-CH-MLD 4.7UH +-5% .166D-INX.	03273	15M471J
L2	9100-1624	9	1	INDUCTOR RF-CH-MLD 30UH +-5% .166D-INX.3	03273	15M302J
L3	9100-0539	3	1	INDUCTOR RF-CH-MLD 10UH +-5% .166D-INX.3	03273	15M102J
L4	9140-0266	7	1	INDUCTOR RF-CH-MLD 1.8UH +-5% .166D-INX.	03273	15M181J

**HP Part Number 08590-60158**  
**BW Filter**

Reference Designation	HP Part Number	C D	Qty	Description	Mfr Code	Mfr Part Number
L5	9100-1624	9	1	INDUCTOR RF-CH-MLD 30UH +-5% .166D-INX.3	03273	15M302J
L6	9100-0539	3	1	INDUCTOR RF-CH-MLD 10UH +-5% .166D-INX.3	03273	15M102J
L7	08590-80120	8	1		28480	08590-80120
L8	9100-0539	3	1	INDUCTOR RF-CH-MLD 10UH +-5% .166D-INX.3	03273	15M102J
L9	9140-0453	4	1	INDUCTOR RF-CH-MLD 6.8UH +-5% .166D-INX.	03273	15M-681J
L10	9140-0142	8	1	INDUCTOR RF-CH-MLD 2.2UH +-10% .105D-INX	03273	10M221K
L11	9100-0539	3	1	INDUCTOR RF-CH-MLD 10UH +-5% .166D-INX.3	03273	15M102J
L12	9140-0266	7	1	INDUCTOR RF-CH-MLD 1.8UH +-5% .166D-INX.	03273	15M181J
L13	9100-1624	9	1	INDUCTOR RF-CH-MLD 30UH +-5% .166D-INX.3	03273	15M302J
L14	9100-0539	3	1	INDUCTOR RF-CH-MLD 10UH +-5% .166D-INX.3	03273	15M102J
L15	08590-80120	8	1		28480	08590-80120
L16	9100-0539	3	1	INDUCTOR RF-CH-MLD 10UH +-5% .166D-INX.3	03273	15M102J
L17	9140-0453	4	1	INDUCTOR RF-CH-MLD 6.8UH +-5% .166D-INX.	03273	15M-681J
L18	9100-1633	0	1	INDUCTOR RF-CH-MLD 68UH +-5% .166D-INX.3	03273	15M682J
L19	9140-0144	0	1	INDUCTOR RF-CH-MLD 4.7UH +-10% .105D-INX	03273	10M471K
Q1	1854-0345	8	1	TRANSISTOR NPN 2N5179 SI TO-72 PD=200MW	02037	2N5179
Q2	1854-0477	7	1	TRANSISTOR NPN 2N2222A SI TO-18 PD=500MW	02037	2N2222A
Q3	1853-0007	7	1	TRANSISTOR PNP 2N3251 SI TO-18 PD=360MW	02037	2N3251
Q4	1853-0007	7	1	TRANSISTOR PNP 2N3251 SI TO-18 PD=360MW	02037	2N3251
Q5	1853-0007	7	1	TRANSISTOR PNP 2N3251 SI TO-18 PD=360MW	02037	2N3251
Q6	1855-0267	5	1	TRANSISTOR J-FET N-CHAN D-MODE TO-92 SI	02037	
Q7	1854-0477	7	1	TRANSISTOR NPN 2N2222A SI TO-18 PD=500MW	02037	2N2222A
Q8	1853-0007	7	1	TRANSISTOR PNP 2N3251 SI TO-18 PD=360MW	02037	2N3251
Q9	1853-0007	7	1	TRANSISTOR PNP 2N3251 SI TO-18 PD=360MW	02037	2N3251
Q10	1853-0007	7	1	TRANSISTOR PNP 2N3251 SI TO-18 PD=360MW	02037	2N3251
Q11	1855-0267	5	1	TRANSISTOR J-FET N-CHAN D-MODE TO-92 SI	02037	
Q12	1853-0007	7	1	TRANSISTOR PNP 2N3251 SI TO-18 PD=360MW	02037	2N3251
R1	0757-0444	1	1	RESISTOR 12.1K +-1% .125W TF TC=0+-100	00746	CRB14 OR CRB25
R2	0698-3156	2	1	RESISTOR 14.7K 1% .125W TF TC=0+-100	00746	CRB14 OR CRB25
R3	0698-7205	0	1	RESISTOR 51.1 +-1% .05W TF TC=0+-100	00746	CRB20
R4	0757-0439	4	1	RESISTOR 6.81K +-1% .125W TF TC=0+-100	00746	CRB14 OR CRB25
R5	0698-7205	0	1	RESISTOR 51.1 +-1% .05W TF TC=0+-100	00746	CRB20
R6	0757-1094	9	1	RESISTOR 1.47K +-1% .125W TF TC=0+-100	00746	CRB14 OR CRB25
R7	0757-0401	0	1	RESISTOR 100 +-1% .125W TF TC=0+-100	00746	CRB14 OR CRB25
R8	8159-0005	0	1	RESISTOR 0 CWM	01339	L-2007-1
R9	0698-3431	6	1	RESISTOR 23.7 1% .125W TF TC=0+-100	00746	CRB14 OR CRB25
R10	0757-0405	4	1	RESISTOR 162 +-1% .125W TF TC=0+-100	00746	CRB14 OR CRB25
R11	0757-0401	0	1	RESISTOR 100 +-1% .125W TF TC=0+-100	00746	CRB14 OR CRB25
R12	0698-0082	7	1	RESISTOR 464 1% .125W TF TC=0+-100	00746	CRB14 OR CRB25
R13	0757-0447	4	1	RESISTOR 16.2K +-1% .125W TF TC=0+-100	00746	CRB14 OR CRB25
R14	0757-0180	2	1	RESISTOR 31.6 +-1% .125W TF TC=0+-100	00746	CRB14 OR CRB25
R15	0757-0440	7	1	RESISTOR 7.5K +-1% .125W TF TC=0+-100	00746	CRB14 OR CRB25
R16	0698-7205	0	1	RESISTOR 51.1 +-1% .05W TF TC=0+-100	00746	CRB20
R17	0757-0419	0	1	RESISTOR 681 +-1% .125W TF TC=0+-100	00746	CRB14 OR CRB25
R18	0698-7216	3	1	RESISTOR 147 +-1% .05W TF TC=0+-100	00746	CRB20
R19	0698-3442	9	1	RESISTOR 237 1% .125W TF TC=0+-100	00746	CRB14 OR CRB25
R20	0698-3440	7	1	RESISTOR 196 1% .125W TF TC=0+-100	00746	CRB14 OR CRB25
R21	0698-3152	8	1	RESISTOR 3.48K 1% .125W TF TC=0+-100	00746	CRB14 OR CRB25

*\*Indicates factory-selected value*

# HP Part Number 08590-60158

## BW Filter

Reference Designation	HP Part Number	C D	Qty	Description	Mfr Code	Mfr Part Number
R22	0698-3154	0	1	RESISTOR 4.22K 1% .125W TF TC=0+-100	00746	CRB14 OR CRB25
R23	0757-0442	9	1	RESISTOR 10K +-1% .125W TF TC=0+-100	00746	CRB14 OR CRB25
R24	0698-3136	8	1	RESISTOR 17.8K 1% .125W TF TC=0+-100	00746	CRB14 OR CRB25
R25	0757-0458	7	1	RESISTOR 51.1K +-1% .125W TF TC=0+-100	00746	CRB14 OR CRB25
R26	2100-3056	8	1	RESISTOR-TRMR 5K 10% TKF SIDE-ADJ 17-TRN	03744	3006P-DM3-502
R27	0757-0442	9	1	RESISTOR 10K +-1% .125W TF TC=0+-100	00746	CRB14 OR CRB25
R28	0698-3154	0	1	RESISTOR 4.22K 1% .125W TF TC=0+-100	00746	CRB14 OR CRB25
R29	0757-0442	9	1	RESISTOR 10K +-1% .125W TF TC=0+-100	00746	CRB14 OR CRB25
R30	0757-0444	1	1	RESISTOR 12.1K +-1% .125W TF TC=0+-100	00746	CRB14 OR CRB25
R31	2100-3052	4	1	RESISTOR-TRMR 50 10% TKF SIDE-ADJ 17-TRN	03744	3006P-DM3-500
R32	0757-0443	0	1	RESISTOR 11K +-1% .125W TF TC=0+-100	00746	CRB14 OR CRB25
R33	0757-0428	1	1	RESISTOR 1.62K +-1% .125W TF TC=0+-100	00746	CRB14 OR CRB25
R34	0698-7212	9	1	RESISTOR 100 +-1% .05W TF TC=0+-100	00746	CRB20
R35	0698-7205	0	1	RESISTOR 51.1 +-1% .05W TF TC=0+-100	00746	CRB20
R36	0698-7205	0	1	RESISTOR 51.1 +-1% .05W TF TC=0+-100	00746	CRB20
R37	0757-0288	1	1	RESISTOR 9.09K +-1% .125W TF TC=0+-100	00746	CRB14 OR CRB25
R38	0698-0083	8	1	RESISTOR 1.96K 1% .125W TF TC=0+-100	00746	CRB14 OR CRB25
R39	0757-0401	0	1	RESISTOR 100 +-1% .125W TF TC=0+-100	00746	CRB14 OR CRB25
R40	0698-0082	7	1	RESISTOR 464 1% .125W TF TC=0+-100	00746	CRB14 OR CRB25
R41	0757-0447	4	1	RESISTOR 16.2K +-1% .125W TF TC=0+-100	00746	CRB14 OR CRB25
R42	0757-0180	2	1	RESISTOR 31.6 +-1% .125W TF TC=0+-100	00746	CRB14 OR CRB25
R43	0757-0440	7	1	RESISTOR 7.5K +-1% .125W TF TC=0+-100	00746	CRB14 OR CRB25
R44	0698-7205	0	1	RESISTOR 51.1 +-1% .05W TF TC=0+-100	00746	CRB20
R45	0757-0419	0	1	RESISTOR 681 +-1% .125W TF TC=0+-100	00746	CRB14 OR CRB25
R46	0698-7216	3	1	RESISTOR 147 +-1% .05W TF TC=0+-100	00746	CRB20
R47	0698-3442	9	1	RESISTOR 237 1% .125W TF TC=0+-100	00746	CRB14 OR CRB25
R48	0698-3441	8	1	RESISTOR 215 1% .125W TF TC=0+-100	00746	CRB14 OR CRB25
R49	0698-3152	8	1	RESISTOR 3.48K 1% .125W TF TC=0+-100	00746	CRB14 OR CRB25
R50	0698-3154	0	1	RESISTOR 4.22K 1% .125W TF TC=0+-100	00746	CRB14 OR CRB25
R51	0757-0442	9	1	RESISTOR 10K +-1% .125W TF TC=0+-100	00746	CRB14 OR CRB25
R52	0698-3136	8	1	RESISTOR 17.8K 1% .125W TF TC=0+-100	00746	CRB14 OR CRB25
R53	0757-0458	7	1	RESISTOR 51.1K +-1% .125W TF TC=0+-100	00746	CRB14 OR CRB25
R54	0757-0442	9	1	RESISTOR 10K +-1% .125W TF TC=0+-100	00746	CRB14 OR CRB25
R55	0698-3154	0	1	RESISTOR 4.22K 1% .125W TF TC=0+-100	00746	CRB14 OR CRB25
R56	0757-0442	9	1	RESISTOR 10K +-1% .125W TF TC=0+-100	00746	CRB14 OR CRB25
R57	0757-0444	1	1	RESISTOR 12.1K +-1% .125W TF TC=0+-100	00746	CRB14 OR CRB25
R58	0757-0443	0	1	RESISTOR 11K +-1% .125W TF TC=0+-100	00746	CRB14 OR CRB25
R59	0698-3154	0	1	RESISTOR 4.22K 1% .125W TF TC=0+-100	00746	CRB14 OR CRB25
R60	0757-0346	2	1	RESISTOR 10 +-1% .125W TF TC=0+-100	00746	CRB14 OR CRB25
R61	0698-3441	8	1	RESISTOR 215 1% .125W TF TC=0+-100	00746	CRB14 OR CRB25
R62	0698-7205	0	1	RESISTOR 51.1 +-1% .05W TF TC=0+-100	00746	CRB20
R63	0698-7212	9	1	RESISTOR 100 +-1% .05W TF TC=0+-100	00746	CRB20
R64	0698-3444	1	1	RESISTOR 316 1% .125W TF TC=0+-100	00746	CRB14 OR CRB25
R65	0757-0346	2	1	RESISTOR 10 +-1% .125W TF TC=0+-100	00746	CRB14 OR CRB25
R66	0757-0401	0	1	RESISTOR 100 +-1% .125W TF TC=0+-100	00746	CRB14 OR CRB25
R67	0757-0401	0	1	RESISTOR 100 +-1% .125W TF TC=0+-100	00746	CRB14 OR CRB25
R68	0757-0442	9	1	RESISTOR 10K +-1% .125W TF TC=0+-100	00746	CRB14 OR CRB25
R69	0698-3152	8	1	RESISTOR 3.48K 1% .125W TF TC=0+-100	00746	CRB14 OR CRB25

## HP Part Number 08590-60158

### BW Filter

Reference Designation	HP Part Number	C D	Qty	Description	Mfr Code	Mfr Part Number
R70	0698-3156	2	1	RESISTOR 14.7K 1% .125W TF TC=0+-100	00746	CRB14 OR CRB25
R71	0698-0083	8	1	RESISTOR 1.96K 1% .125W TF TC=0+-100	00746	CRB14 OR CRB25
R72	0757-0346	2	1	RESISTOR 10 +-1% .125W TF TC=0+-100	00746	CRB14 OR CRB25
R73	0757-0346	2	1	RESISTOR 10 +-1% .125W TF TC=0+-100	00746	CRB14 OR CRB25
R74	0698-7264	1	1	RESISTOR 14.7K +-1% .05W TF TC=0+-100	00746	CRB20
TP1	1252-3104	7	1	CONN-POST TYPE .100-PIN-SPCG 2-CONT	02946	68016-102
TP2	1252-3104	7	1	CONN-POST TYPE .100-PIN-SPCG 2-CONT	02946	68016-102
TP3	0360-2050	8	1	CONNECTOR-SGL CONT	04055	
TP4	1252-3104	7	1	CONN-POST TYPE .100-PIN-SPCG 2-CONT	02946	68016-102
TP5	1252-3104	7	1	CONN-POST TYPE .100-PIN-SPCG 2-CONT	02946	68016-102
TP6	0360-2050	8	1	CONNECTOR-SGL CONT	04055	
TP7	0360-2050	8	1	CONNECTOR-SGL CONT	04055	
TP8	0360-2050	8	1	CONNECTOR-SGL CONT	04055	
TP9	0360-2050	8	1	CONNECTOR-SGL CONT	04055	
U1	1826-0915	9	1	IC OP AMP LOW-BIAS-H-IMPD 8-DIP-C PKG	01698	TL071ACJG (PER HP DWG)
VR1	1902-0954	8	1	DIODE-ZNR 6.8V 5% DO-35 PD=.4W TC=+.057%	02037	
Y1	0410-2118	6	1	CRYSTAL-QUARTZ 21.4MHZ SET OF 4	03747	
Y2	0410-2118	6	1	CRYSTAL-QUARTZ 21.4MHZ SET OF 4	03747	

\*Indicates factory-selected value





 <b>HEWLETT PACKARD</b>		08590-60158 <small>PAGE NUMBER</small>
BD ASSEMBLY- BANDWIDTH FILTER		08590-60158-2 <small>FILE NUMBER</small>
TITLE 2X	1 <small>REV. OF</small>	1 <small>REV. OF</small>
DESIGNED BY DATE	ENGINEER/CHECKER	SUPERVISOR ENG.
UNLESS OTHERWISE SPECIFIED DIMENSIONS ARE IN INCHES		TOLERANCES UNLESS OTHERWISE SPECIFIED .0005" .001" .002" .005" .010" .015" .020" .030" .040" .050" .060" .070" .080" .090" .100" .125" .150" .175" .200" .250" .300" .375" .450" .500" .625" .750" .875" 1.000" 1.250" 1.500" 1.750" 2.000"
SEE COMP. STD. 808		SEE COMP. STD. 808

HP PROPRIETARY  
 THIS DOCUMENT CONTAINS CONFIDENTIAL  
 PROPRIETARY INFORMATION THAT IS  
 HEWLETT-PACKARD (HP) PROPERTY. DO  
 NOT DISCLOSE TO OR DUPLICATE FOR  
 OTHERS EXCEPT AS AUTHORIZED BY HP.

SEE 08590-60158 MATERIAL LIST

- NOTES: UNLESS OTHERWISE SPECIFIED
1. DIMENSIONS ARE IN INCHES.
  2. MAXIMUM COMPONENT HEIGHT .400
  3. MAXIMUM LEAD TRIM LENGTH .070
  4. L2 AND L15 MUST BE TIGHT TO BOARD SURFACE AFTER MACHINE SOLDER.
  5. CHECK FOR MODIFICATIONS IN THE P.C.LINE ASSEMBLY DOCUMENTATION MANUAL R-08590-R11/R13.

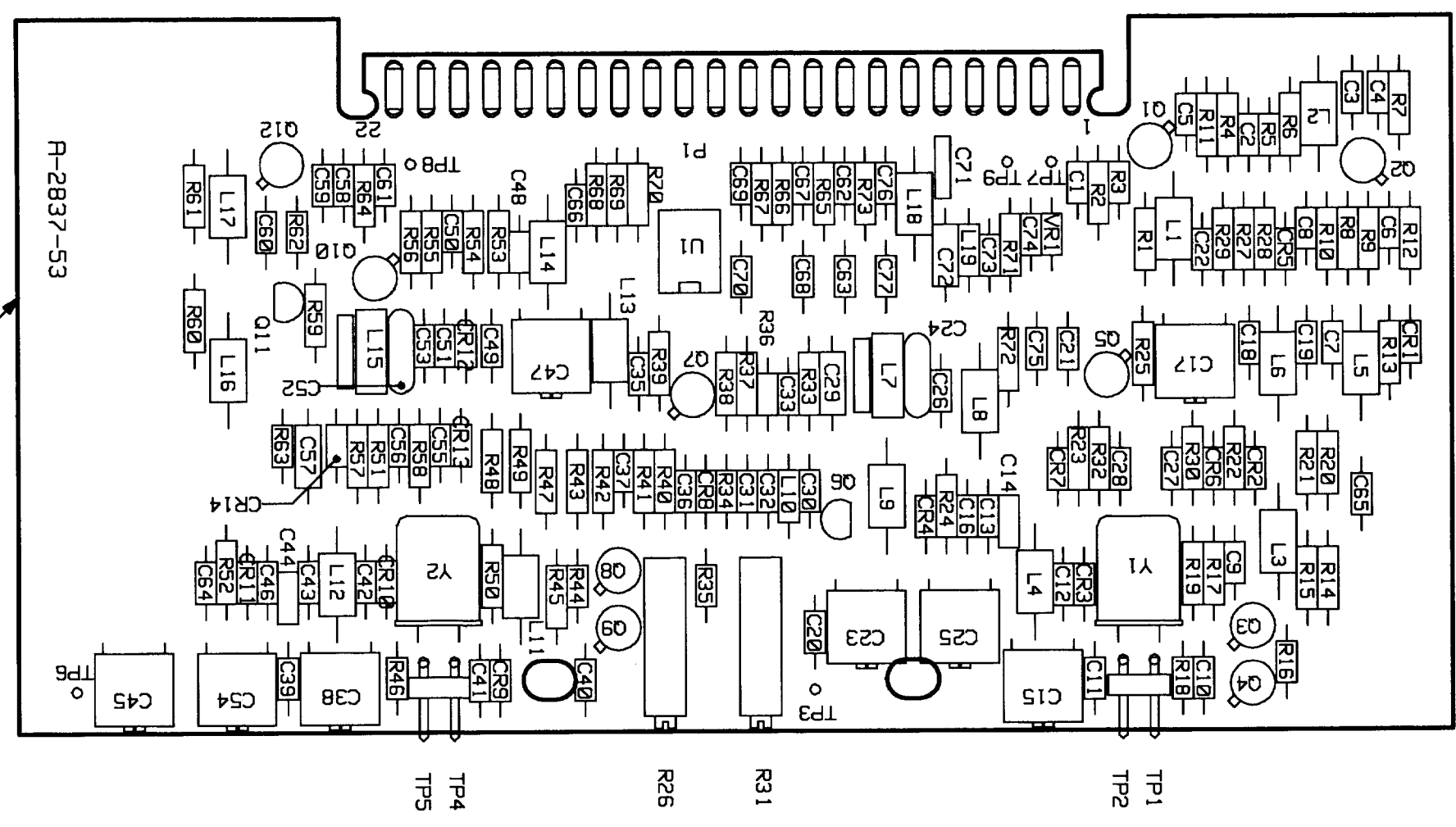

SYM	REVISIONS	APPROVED	DATE
A			

D-08590-60158-2